

Starter Switch

STARTER SWITCH OPERATION

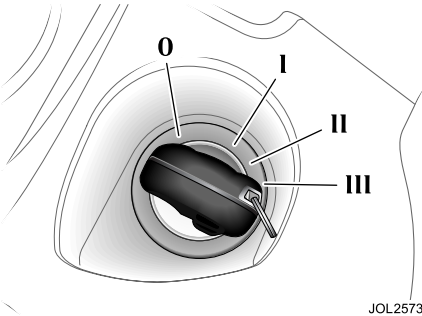

The starter switch, on the right-hand side of the steering column, has four key positions:

- 0** OFF.
- I** Auxiliary.
- II** ON.
- III** Engine start.

Position 0: Is the only position in which the key can be inserted and removed.

Position I: Allows use of some electrical circuits, for example, radio operation.

Position II: All electrical circuits except the starter motor are activated. The key remains in this position when driving.

Position III: The starter motor is operated.

TO REMOVE THE STARTER KEY

Manual transmission vehicles

Apply the handbrake and turn the key to position **0**. The key can then be removed from the switch.

Automatic transmission vehicles

Automatic transmission vehicles have a key interlock feature.

Apply the handbrake, place the gear selector in **P** and turn the key to position **0**.

The automatic transmission gear selector must be placed in Park **P** before the key can be removed from the starter switch. When the key is removed, the gear selector will be locked in Park.

GEARSHIFT INTERLOCK

A brake pedal/gearshift interlock system is incorporated in the automatic transmission gear selector mechanism.

To move the gear selector from Park:

1. Turn the starter key to position **II** or start the engine.
2. Press the brake pedal.

STEERING COLUMN LOCK

When the starter key is removed, the steering column lock is engaged. The lock is disengaged when the key is inserted into the starter switch and turned to position **I**.

In rare circumstances it may be necessary to gently turn the steering wheel from side to side to release the steering column lock.

Vehicle Security

SECURITY OVERVIEW

When leaving the vehicle unoccupied, remember the following:

- Apply the handbrake and with automatic transmission, move the gear selector to Park **P**.
- Do not leave children or pets in the vehicle unattended.
- Do not leave luggage or valuables on view. Always take your valuables with you or lock them in the luggage compartment.
- Remove the starter key and spare keys, even when the vehicle is in your garage.
- Close all windows and lock all doors securely.
- Park the vehicle where it can be seen. At night, park in a well-lit area.
- When leaving the vehicle unattended, for maximum security ensure that the doors are double-locked.

Ensure that all key transmitters are removed from the vehicle before locking the doors, and that all doors, the luggage compartment and the bonnet are closed.

It is important to keep your keys in safe places at all times. Leaving them in conspicuous places is an invitation for a thief to steal them and, consequently, your vehicle or belongings. Keep them as secure as you would your wallet or purse, both at home and away.

IMMOBILISER SECURITY LAMP

This vehicle is equipped with an immobilisation system.

An electronic device is fitted in the head of each key which is programmed to the vehicle electronics. When the key is placed in the starter switch the vehicle electronics recognise the correct key and allow engine start. The engine cannot be started with a key not programmed to the vehicle electronic systems.

If a starter key is placed in the starter switch and turned to position **II** and the alarm security lamp on the centre console remains flashing after three seconds, it is possible that the engine will not start. In any event, please contact a Jaguar Dealer/ Authorised Repairer to investigate the cause of the lamp flashing.

KEYS

This vehicle is supplied with a key integrated with the remote transmitter. This key operates all the locks on your vehicle. Vehicles are supplied with two integrated keys.

The key number is recorded on a plastic tag, which is attached to each key. Detach the tag and keep safely, not in the vehicle.

Vehicle Security

KEY TRANSMITTER



WARNING:

Never leave the key transmitter in the vehicle if children or animals are also left in the vehicle. The vehicle's systems and remote control functions could be operated, which may result in injury.



JAG0667

The security system is controlled remotely by a radio frequency, battery-operated transmitter.

The transmitter is activated by pressing one of the operating buttons:



Unlocks and disarms the vehicle.



Releases luggage compartment lock.



Activates the convenience headlamp feature and sounds the panic alarm.



Locks, double-locks and arms the vehicle.



To free the key, press the release button. When not required press and hold the button and fold the key into the transmitter housing.

Note:

- The key transmitter may not operate correctly in areas which are subject to interference from other radio equipment operating on the same frequency. Interference may emanate from sources such as amateur radio, medical equipment, telecommunications devices and other remote controls or alarms. Where such interference is experienced, operate the key transmitter as close as possible to the vehicle, or use the key in the driver's door lock.
- All buttons on the key transmitter will not operate if a key is in the starter switch, however, if the doors, bonnet or luggage compartment are open, only the lock button will not operate.

Additional key transmitters can be obtained from your Jaguar Dealer/ Authorised Repairer and can be used provided a Dealer programmes them all to the vehicle.

Caution: Should a key transmitter be lost, a new one can be obtained and programmed to the vehicle by a Jaguar Dealer/Authorised Repairer, who will ask for proof of vehicle ownership. It is advisable to notify a Dealer as soon as a key transmitter is lost or stolen and have the remaining key transmitter(s) reprogrammed. This will then prevent the lost or stolen key transmitter from being used to disarm and unlock the vehicle.

Vehicle Security

Note: Dealers keep a log of all enquiries for replacement keys and notify Jaguar Cars Limited of any such requests.

European and United Kingdom countries only

The alarm system will not be fully armed unless the vehicle is double-locked. See “Double-locking” on page 50.

Care of key transmitters

The key transmitters must be treated with care. Do not expose to extremes of heat, dust, humidity or fluids. Do not leave the transmitter exposed to direct sunlight. The battery is the only serviceable part.

RADIO FREQUENCY APPROVAL

If the type approval of your key transmitter requires inspection, refer to the table below:

Type Exam. Certificate Number:
CERT 980154-01

Country	Approval No.
All EU and EFTA countries	CE 0700 ⚠

Caution: The key transmitter may suffer interference from other legal users of this radio frequency band, such as radio amateurs, medical equipment, remote controls or alarm systems. To lock or unlock the vehicle, either use a key or operate the transmitter as close to the security antenna on the rear screen as possible.

Vehicle Security

TRANSMITTER BATTERY RENEWAL

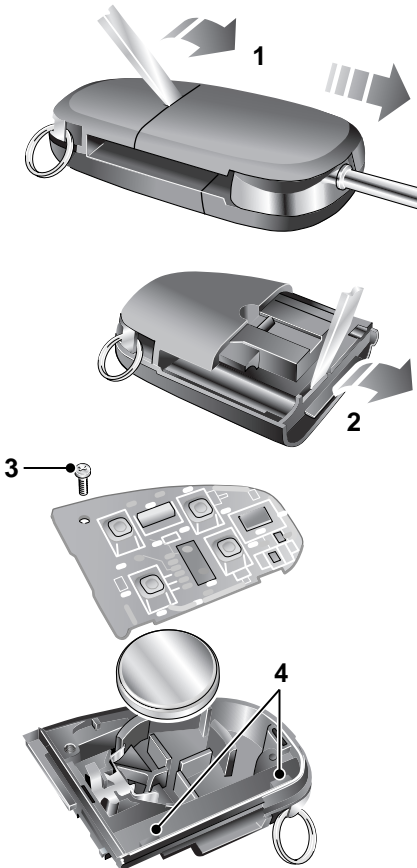

JAG0822

When the battery needs renewal there will be a significant decrease in the effective range of the key transmitter. To renew the battery, follow the procedure below:

- Insert a small, flat-blade, screwdriver at an angle of about 45 degrees, into the slot on the back of the key transmitter as shown (1). Apply light pressure to the screwdriver and lever the screwdriver forward to separate the two halves of the key transmitter. Pull the transmitter from the key body.
- Insert the screwdriver into the slot between the transmitter covers adjacent to the key storage area as shown (2). Apply light pressure to the screwdriver and lever the screwdriver downward to separate the covers.
- Unscrew and remove the small screw (3) and remove the printed circuit board, taking care not to touch the battery terminals. Remove the battery and dispose of it safely.
- Fit a new battery cell, type CR2032 (available from your Jaguar Dealer/ Authorised Repairer), with the side marked with the positive symbol (+) downwards in the battery receptacle. Avoid touching the new battery as moisture/oil from the fingers can reduce the life of the battery and corrode the contacts.
- Replace the printed circuit board making sure to engage the board under the securing tabs (4), and secure with the screw.
- Refit the cover and click into place with thumb pressure.
- Slide the transmitter back onto the key body until it clicks into place.

Door Locks

OPERATION

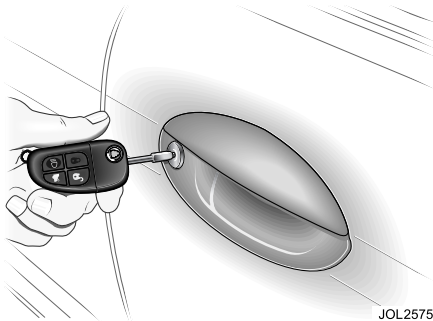

All doors can be locked and unlocked either remotely using the key transmitter buttons, or by using the integrated key.

SMART LOCKING

This feature helps prevent locking the key in the vehicle. If one of the front doors is open and an attempt is made to lock the doors using a door interior locking lever, all doors will become unlocked.

If the bonnet, luggage compartment or a door is open, the vehicle can only be locked from the outside by using a key in the driver's door lock.

It will not be possible to lock the vehicle with a key transmitter if the luggage compartment, bonnet or a door is open.

LOCKING AND UNLOCKING

To lock the vehicle and set the alarm

- Press the lock button on the key transmitter, or;
- Put the key into the driver's door lock, turn the key towards the rear of the vehicle and release.

The direction indicators will flash once, the security lamp on the centre console will start flashing and, after 20 seconds, the alarm will be set.

Note:

- *This will not arm the alarm system's intrusion sensors (where fitted). The intrusion sensors are only armed if the vehicle is double-locked. See "Double-locking" on page 50.*
- *Do not double-lock the vehicle if people or pets are to be left inside: their movement will trigger the alarm. If the vehicle is single-locked, the main alarm features will still function, but the intrusion sensors will be disarmed.*

WARNING:

Do not leave people or pets in the vehicle on warm, sunny days: the interior temperature can rise rapidly to dangerous levels.

If a door, the bonnet or the luggage compartment lid are open and an attempt is made to lock the vehicle, the direction indicators will flash five times and the horn will chirp twice as a warning that the vehicle is not secure.

Note: *Ensure that the manually operated rear windows are fully closed by hand (if fitted).*

Door Locks

To unlock the vehicle and disarm the alarm system using a key:

- Put the key in the driver's door lock, turn the key towards the front of the vehicle and release.

Single-stage unlocking - This unlocks all doors and the luggage compartment and turns on the interior lamps.

Two-stage unlocking - This only unlocks the driver's door (and the Saloon luggage compartment) and turns on the interior lamps. A second turn of the key is required to unlock all doors (and the Estate tailgate).

European and United Kingdom countries only: If the vehicle is unlocked with a key, a chime will sound when the driver's door is opened. This is a warning to indicate that the vehicle alarm will activate after 15 seconds unless the security system is disarmed by either pressing the unlock button on the key transmitter or by placing the key into the starter switch and turning the key to position I.

Note:

- *If a passenger door is opened during this period, before the vehicle is disarmed, the alarm will sound.*
- *The security system is not disarmed when unlocking with the key as additional protection against vehicle theft.*

For all other countries: Unlocking the vehicle disarms the alarm system.

To unlock the vehicle and disarm the alarm system using a key transmitter:

- Press the unlock button on the key transmitter.

Single-stage unlocking - This unlocks all doors and the luggage compartment and turns on the interior lamps.

Two-stage unlocking - This only unlocks the driver's door (and the Saloon luggage compartment) and turns on the interior lamps. A second press of the button is required to unlock all doors (and the Estate tailgate).

Direction indicator unlock alerts

The exterior direction indicators give two flashes as unlocking takes place.

Note: *The exterior direction indicators will flash five times if a fault exists with the intrusion sensing or inclination sensing systems.*

Selecting single-stage or two-stage unlocking

The procedure for changing from single-stage to two-stage unlocking, or vice versa, is as follows:

- Press and hold the lock and unlock buttons on the key transmitter simultaneously for four seconds.

Note: *The direction indicators will flash twice to confirm the procedure was successful.*

To revert to the previous condition, repeat the procedure described above.

Door Locks

Global closing



WARNING:

Ensure that no children, pets, or obstructions are in any open aperture before operating global closing. Safety mechanisms are in place to prevent serious injury, however, injuries can still occur.

Key in the driver's door: Turn and hold in the lock position to close all the electrically operated windows (and sunroof, if fitted).

Key transmitter: Press and hold the lock button for longer than 1½ seconds to close all the electrically operated windows (and sunroof, if fitted). Pressing the button again while global closing is taking place will stop all movement.

Note: *Ensure that manually operated rear windows are fully closed by hand (if fitted).*

Internal door locking and unlocking

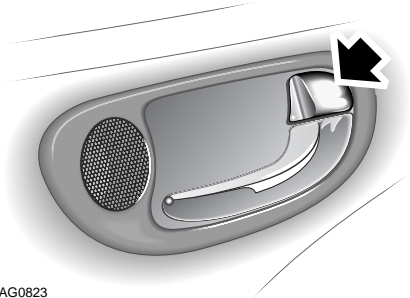

JAG0823

To lock all doors centrally, press the lock lever on either the driver's or the front passenger's door.

To lock a rear door, press the lock lever.

To unlock a door, pull the lock lever.

To open a locked door, pull the release handle.

The driver's or front passenger's door lock lever will unlock all doors.



WARNING:

When an interior door release lever is pulled, the door will unlatch.

Door Locks

Double-locking



WARNING:

Never double-lock the vehicle with people, children, or pets inside. In the event of an emergency they would be unable to escape, and the emergency services would be unable to release them quickly.

Note: It will not be possible to double-lock the vehicle if any door is open, a key is in the starter switch or the inertia switch has been tripped.

With all doors, luggage compartment, and bonnet closed, and no key in the starter switch, press the lock button on the key transmitter twice within three seconds to double-lock the vehicle and set the alarm.

Alternatively, place the key in the driver's door lock, turn the key towards the front of the vehicle and then towards the rear within three seconds to set the alarm.

The exterior direction indicators will flash once as locking takes place and a longer, second flash as double-locking takes place. An audible tone will be produced to confirm that the vehicle has been double-locked.

Auto-relocking

Note: This feature is normally disabled. A Jaguar Dealer/Authorised Repairer can enable this feature, if required.

This feature automatically centrally locks and arms the vehicle if the vehicle has been unlocked with the key transmitter:

- and no door has been opened for 45 seconds or,
- if the starter remains off for 45 seconds.

Drive-away door locking

With the starter key at position **II** and all doors closed, all doors will lock when the vehicle is moving above 5mph (8 km/h). If the vehicle is stopped and a door is opened, provided the engine remains running, the car will relock when the door is closed and the vehicle is moving. If the car is unlocked this feature will only lock the doors again if the starter switch is turned off and then back on.

All vehicles have the drive-away door locking feature installed during manufacture. This feature can be disabled, or reinstated, by a Jaguar Dealer/Authorised Repairer if required.

Door Locks

CHILD SAFETY LOCKS

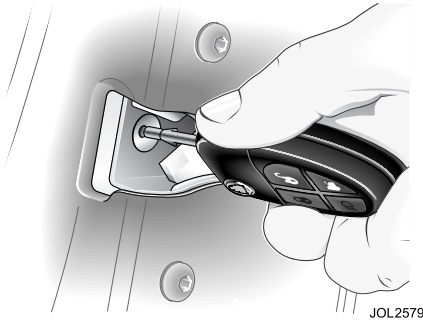

Child safety locks are fitted to the rear doors.

Open a rear door, insert the starter key into the lock and turn the key towards the outside of the vehicle. This immobilises that door interior handle. Repeat this for the opposite rear door.

After setting the child lock the door(s) can only be opened using the exterior door handle.

To remove the child lock feature, open the door and using a key, move the control to its original unlock position.

Luggage Compartment Locks

LUGGAGE COMPARTMENT



If the vehicle alarm system is armed and the luggage compartment is opened using the key transmitter the alarm will not sound. The system will be rearmed when the lid is closed, provided the vehicle has not been disarmed.

Saloon

To open the luggage compartment:

- Press the luggage compartment button **1** on the key transmitter or,
- With the vehicle unlocked, press the release button **2** on the luggage compartment lid.

The luggage compartment will be illuminated when the lid is opened.

Estate

Open the tailgate by pressing the release button **2** under the tailgate trim.

The tailgate can also be opened by pressing the luggage compartment button **1** on the key transmitter.

The luggage compartment will be illuminated when the tailgate is opened.

Note: If required, the key transmitter can be reprogrammed so that button **1** will open the Estate tailgate glass, instead of the tailgate. Contact your Jaguar Dealer/Authorised Repairer to have this feature enabled.

Luggage Compartment Locks

Opening the tailgate glass

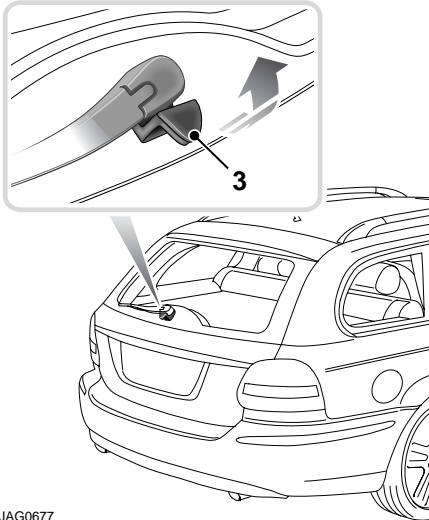

JAG0677



WARNING:

Do not drive with the tailgate glass open as exhaust fumes can be drawn into the passenger compartment.

The tailgate glass can be opened separately from the complete tailgate. Press the release button **3**, located on the reverse of the tailgate glass handle, and lift the tailgate glass.

Alarm Systems

AUDIBLE SIGNALS

Note: *In certain countries, legislation prohibits the use of audible confirmation signals. In such cases, the sound source has been removed from the system.*

Two horn chirps will sound if an attempt is made to lock the vehicle with the key transmitter if a door, the bonnet or the luggage compartment is not fully closed.

European/United Kingdom countries only

If the vehicle is unlocked with a key when it is armed, a chime will sound when the driver's door is opened. This is a warning to indicate that the vehicle alarm will activate after 15 seconds unless the security system is disarmed with either the key transmitter or by turning the starter key to position I.

If the vehicle is unlocked with a key when it is armed and any door other than the driver's door is opened, the alarm will sound immediately.

ERROR SIGNAL

The direction indicators will flash five times whenever one of the following conditions is present:

- Any door is open when an attempt is made to lock the vehicle.
- The luggage compartment or the bonnet is not properly closed when an attempt is made to lock the vehicle.
- If there is an electrical failure within the intrusion sensing or inclination sensing systems and an attempt to disarm the security system is made.

FULL ALARM

Once armed, any of the following circumstances will create a full alarm state, sound the horns and flash the direction indicators:

- Opening a door, luggage compartment lid or tailgate (except with transmitter) or bonnet.
- Movement in the passenger area (if intrusion sensors are fitted).
- Using a key in the starter switch which is not programmed to the vehicle.
- If, after 15 seconds from opening the driver's door with a key (European countries and United Kingdom only), the key is not inserted into the starter switch.
- If the inclination sensor (if fitted) is activated.
- Any attempt is made to remove the radio.

SECURITY FEATURES

The security system has been designed for:

- Prevention of theft of the vehicle.
- Prevention of theft of items from the vehicle.
- Personal security.

The security system is integrated with the vehicle electronics and engine management systems making it far more difficult for a thief to penetrate and steal the vehicle.

Alarm Systems

Intrusion sensing (Where fitted)

A further enhancement to the security system is the addition of intrusion sensing. When the vehicle is armed and double-locked, movement within the vehicle interior will activate the alarm. The luggage compartment can be unlocked, using the key transmitter button, without sounding the alarm. When the security system is disarmed the intrusion sensors are also disarmed.

Note: *Ensure that manually operated rear windows are closed before double-locking the vehicle. This will prevent intrusion sensing falsely sounding the alarm.*

Inclination (tilt) sensing protection (Where fitted)

This feature protects against unauthorised towing away or jacking up. When the vehicle is double-locked and armed, any tilting of the vehicle, such as jacking or lifting, will activate the alarm.

Note: *If the vehicle is being transported by road, rail or sea, the vehicle should not be double-locked. This prevents the inclination system from being armed and sounding the alarm as the vehicle pitches and rolls.*

When the security system is disarmed the inclination sensor is also disarmed.

Battery reconnection

If the battery has been disconnected and is subsequently reconnected, the alarm system will resume the same state as before the battery was disconnected.

If the alarm was sounding when the battery was disconnected it will sound again when the battery is reconnected and will need:

- The transmitter unlock button to be pressed or,
- Key placed into the starter switch and turned to position **I** to disarm it.

Panic alarm

When in or near the vehicle, the alarm can be set off to deter a possible offender. For this feature to operate, the key must not be in the starter switch.

Pressing the headlamp convenience/panic button on the key transmitter three times within three seconds will activate the Panic Alarm.

The alarm is stopped by:

- Putting the key into the starter switch and turning to position **II** or,
- Pressing either the transmitter panic button three times or one press of the unlock button.

Battery backed sounder

In certain countries a separate, self-contained, battery backed sounder is fitted. This device will sound the full alarm if the vehicle alarm is activated or if the vehicle battery or the sounder is disconnected when the security system is armed.